

Phosphorus pentoxide with its drying properties removed from the carbon tetrachloride sufficient water to greatly increase the rate of enolization. The resultant acid possibly had a minor effect in the catalysis.

The addition of sulfur was made to see if a mere surface in molecular dispersion had any effect detectable. The negative result seems logical in view of the reaction mechanism.

Acknowledgment.—The authors take this opportunity to express to Dr. E. Emmet Reid their appreciation for his advice and interest in this study, and to Dr. H. S. Taylor and Dr.

Gregg Dougherty for suggestions concerning its presentation.

Summary

1. Rates of photochemical bromination of acetophenone in the presence of varying concentrations of water, hydrogen chloride, phosphorus pentoxide, and sulfur are given.

2. The results obtained in the bromination of acetophenone in the presence of the above agents indicate that the theory of prototropic reaction of carbonyl compounds is applicable even in non-aqueous solvents, *e. g.*, carbon tetrachloride.

PRINCETON, NEW JERSEY RECEIVED JANUARY 8, 1942

[CONTRIBUTION FROM THE DEPARTMENT OF CHEMISTRY, UNIVERSITY OF CALIFORNIA, LOS ANGELES]

The Photolysis of the Aliphatic Aldehydes. X. Acetaldehyde and Iodine Mixtures

BY F. E. BLACET AND JULIUS D. HELDMAN

In the photolysis of the aliphatic aldehydes the nature of the primary process has been an uncertain factor which has caused a great deal of speculation in recent years. By using iodine vapor to remove free radicals, Gorin¹ has presented evidence which appeared to settle the matter for acetaldehyde at wave lengths 3130 and 2600 Å. His work indicated that at both of these wave lengths primary decomposition both into the radicals CH₃ and HCO and into CH₄ and CO occurred. The CH₃ radicals reacted with iodine to give CH₃I and the sums of the quantum yields of CH₃I and CH₄ were equal to unity at each wave length. In the spectral region employed iodine vapor does not absorb.

Gorin's work appeared to warrant repetition and extension to other experimental conditions. In this article are reported results obtained at λ3130. Since others may wish to ascertain why our results differ from those reported by Gorin, experimental methods are described in considerable detail.

Experimental Procedures

Monochromatic light was obtained from an atmospheric pressure mercury arc and a crystal quartz monochromator. The radiant energy was measured by means of a thermopile-galvanometer system which was standardized against two calibrated lamps obtained from the Bureau of Standards. Since the thermopile could not be used at the elevated temperatures employed in this work, the energy

entering the empty cell was measured at room temperature before a run, and the amount absorbed calculated with the aid of previously obtained curves of per cent. absorption *vs.* molecular concentration. The work of Leermakers² and Grahame and Rollefson³ has shown that no serious error is introduced by assuming a constant absorption coefficient over the temperature range used in this study. The light intensity was kept constant during a run by controlling the amperage of the arc.⁴

The reaction system is shown diagrammatically in Fig. 1. That part within the dotted lines can be thermostated at whatever temperature is desired. The fused quartz reaction cell, A, is 3 cm. in diameter and 20 cm. in length. CDE is a magnetic circulating pump.⁵ FGH is a magnetic valve through which acetaldehyde vapor can be introduced into the reaction system from S, and non-condensable reaction products can be collected by means of a Toepler pump placed beyond the mercury trap, J.

After thoroughly drying the reaction system by repeatedly flushing it with dry nitrogen, a weighed amount of iodine in an open capsule was dropped in the trap, B. B was then sealed in such a way that no moisture from the flame entered it. Next, after freezing the iodine with an alcohol-carbon dioxide refrigerant, the nitrogen was removed completely, the thermostat brought to the desired temperature, and the iodine allowed to vaporize into the reaction system. Then with the cut-off trap, I, open, F was raised and acetaldehyde vapor forced through a capillary tube into the reaction system where it was mixed with the iodine vapor by means of the magnetic pump.

After irradiation, all condensable substances were frozen in B by using liquid air, and the non-condensable gases collected for analysis with the aid of the Toepler pump.

(1) (a) Gorin, *Acta Physicochim. U. S. S. R.*, **9**, 681 (1938); (b) *J. Chem. Phys.*, **7**, 256 (1939).

(2) Leermakers, *THIS JOURNAL*, **56**, 1537 (1934).

(3) Grahame and Rollefson, *J. Chem. Phys.*, **8**, 98 (1940).

(4) Blacet and Lu Valle, *THIS JOURNAL*, **61**, 273 (1939).

(5) Blacet and Volman, *ibid.*, **61**, 582 (1939).

Permanent gases absorbed in the condensate in B were removed by pumping off almost all the gas; then after allowing the trap to warm up and freezing it again, the gas collection was finished. It was important that the circulating pump be operated during the freezing process.

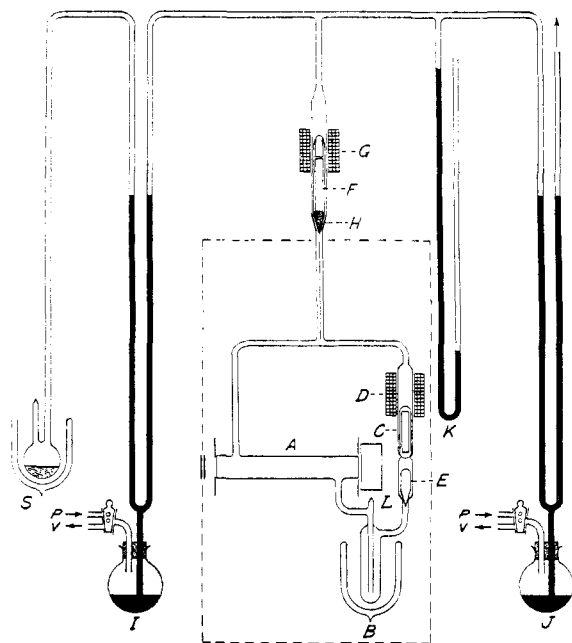

Fig. 1.—Diagram of the photochemical apparatus.

Analytical Methods.—The gaseous products were analyzed with the aid of a Blacet-Leighton apparatus for the microanalysis of gases.

Analyses for products condensable in liquid air were modeled after Gorin's methods.^{1a} The refrigerated trap, B, containing the condensate, was cut out of the system and sealed after a drop of mercury had been added to its contents. It was then warmed to room temperature for a minute or two and refrozen. This step was necessary for complete removal of excess iodine by mercury. The side arm of the trap was then broken open and at once sealed onto an all-glass distillation train consisting of a U-bend of tubing, a tube containing about ten moist potassium hydroxide pellets, and finally a trap containing sodium ethylate in absolute alcohol. This trap was kept refrigerated in a dry-ice-alcohol bath. The train was then evacuated, using a Toepler pump for the final stages, and the system sealed off from the pump.

The cooling bath was removed from the trap, B, and placed around the U-bend. A colorless solution condensed in the U-bend, indicating complete removal of the excess iodine by mercury. This solution was distilled through the potassium hydroxide into the sodium ethylate tube, which subsequently was sealed off. In some instances distillation from the U-tube was made at -30° , following Gorin's procedure, and the residue tested for acetyl iodide.

The sodium ethylate tube was heated at 100° for an hour, and the resulting mixture washed with water into a 125-ml. glass-stoppered flask. The mixture was made acid with buffered acetic acid. Some polymer of acetaldehyde was formed when the acid was added, but it did not

interfere with the analysis. An excess of bromine vapor was poured into the flask, which was thoroughly shaken, and then 1 ml. of 90% formic acid was introduced to destroy the excess bromine. The analysis was carried out by adding 2 ml. of fresh 10% potassium iodide solution to the flask and titrating with freshly prepared 0.005 *N* standard sodium thiosulfate, using 1 ml. of starch indicator. The end-point change was from blue to reddish-brown, the color of the aldehyde polymer. Blanks were run with each set of titrations, but corrections were negligible. The analytical method was found to be satisfactory by testing methyl iodide containing iodine, hydrogen iodide and acetaldehyde as impurities. The potassium hydroxide absorbed all the hydrogen iodide and none of the methyl iodide.

Experimental Results

In Table I are given the quantum yields, Φ , obtained for carbon monoxide, methyl iodide, and methane. The yield for each substance (carbon monoxide, methyl iodide and methane) is the ratio of moles of the particular substance formed in the process to the total einsteins absorbed. All the runs were made at $\lambda 3130$, with constant incident intensity of approximately 2×10^4 ergs per sec. and with an acetaldehyde concentration of 1.00×10^{-2} mole per liter (approximately 200 mm. pressure at room temperature).

TABLE I
QUANTUM YIELDS FOR THE FORMATION OF CARBON MONOXIDE, METHYL IODIDE AND METHANE

| Runs | Temp., °C. | Pressure of iodine, mm. | Φ_{CO} | Φ_{CH_3I} | Φ_{CH_4} |
|----------------|---------------|-------------------------------|-------------|----------------|---------------|
| 1 | 61 | 0.25 | 0.21 | 0.055 | 0.14 |
| 2 | 65 | .42 | | .063 | |
| 3 | 60 | .47 | .11 | .089 | .06 |
| 4 | 60 | 1.0 | .19 | .16 | .01 |
| 5 | 60 | 1.0 | .13 | .16 | .00 |
| 6 | 60 | 2.2 | | .18 | .00 |
| 7 ^a | 61 | 2.2 | .25 | .27 | .02 |
| 8 | 61 | 2.2 | .26 | .19 | .03 |
| 9 | 61 | 2.7 | .19 | .27 | .01 |
| 10 | 60 | 3.3 | .25 | .16 | .02 |
| 11 | 100 | 2.0 | | .25 | .04 |
| 12 | 100 | 2.3 | .19 | .22 | .02 |
| 13 | 115 | 3.3 | .30 | .30 | .01 |
| 14 | 135 | 3.1 | .37 | .38 | .01 |
| 15 | 135 | 3.2 | .21 | .18 | |
| 16 | 145 | 5.0 | .34 | .35 | .01 |
| 17 | 167 | 2.5 | .38 | .31 | .09 |
| 18 | 170 | 2.8 | .40 | .51 | .16 |
| 19 | 61 | 0.0 | .33 | | |
| 20 | 61 | 0.0 | .35 | | .34 |
| 21 | 100 | 0.0 | .80 | | |
| 22 | 135 | 0.0 | 2.29 | | |

^a Runs 7, 8 and 9 were made by D. E. Loeffler.

Analyses for hydrogen in the gaseous products gave negative results within experimental error,

for all runs in which the iodine pressure was over 1 mm. It was demonstrated again^{6,7} that methane is the only hydrocarbon produced in measurable quantity in the photolysis of pure acetaldehyde. Iodide, presumably from hydrogen iodide, was found in the potassium hydroxide tube, but the test can only be considered qualitative, since it is possible that there was some reaction of hydrogen iodide with acetaldehyde. All tests which were made for acetyl iodide gave negative results.

A dark run of acetaldehyde and iodine at 150° gave no detectable reaction products.

Discussion of Results

The reduction of the methane quantum yield, Φ_{CH_4} , from 0.32 (calculated from Φ_{CO} and the CH_4/CO ratio⁷) for pure acetaldehyde at 60°, to an average value of 0.013 for aldehyde and iodine mixtures, eliminates

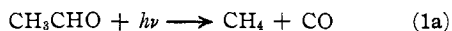

as an important primary process at $\lambda 3130$. With increase of iodine pressure from 0 to 1 mm. there is a continuous decrease of Φ_{CH_4} . Several runs in the 1–3 mm. pressure range gave quantum yields of zero, but experimental errors were such that it cannot be said that above 1 mm. iodine pressure Φ_{CH_4} continues to approach zero. However, it can be said that with adequate iodine present Φ_{CH_4} has an upper limit of 0.013.

With increase of iodine concentration, $\Phi_{\text{CH}_3\text{I}}$ increases from zero at zero iodine pressure to an average value of 0.20 at 60°, in the iodine pressure range of 1 to 3 mm. This fact is consistent with the primary reaction

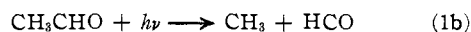

Beyond 1 mm. iodine pressure, if all methyl radicals are removed by iodine, a constant value for $\Phi_{\text{CH}_3\text{I}}$ is to be expected. The absence of a gradual increase in $\Phi_{\text{CH}_3\text{I}}$ above 1 mm. iodine pressure indicates that methyl iodide is not produced from a reaction between iodine and *activated* acetaldehyde.

The carbon monoxide quantum yield at 60° diminishes from 0.34 in the absence of iodine to a constant value of 0.21 in the 1 to 3 mm. iodine pressure range. This constant yield is, within experimental error, equal to that obtained for methyl iodide and suggests that the formyl radicals from (1b) react with iodine to give carbon monoxide and hydrogen iodide. The formation

of no more than a trace of hydrogen in this iodine pressure range leads to the same conclusion. Additional evidence for such a reaction may be found in the results of a photochemical study of formaldehyde and iodine mixtures, reported by Gorin.^{1b} At both $\lambda 3130$ and $\lambda 2537$ he found, with sufficient iodine present in the reaction system, that very little hydrogen was produced, and the ratio of hydrogen iodide to carbon monoxide was approximately two. Since at $\lambda 3130$ there is insufficient energy to dissociate formaldehyde directly into two hydrogen atoms and one carbon monoxide molecule, it seems probable that the primary process is the formation of one hydrogen atom and the formyl radical. To account for the above-mentioned ratio of two, Gorin assumed that hydrogen atoms react with iodine to give hydrogen iodide, but that two formyl radicals react with one another to give one molecule of formaldehyde back again and a molecule of carbon monoxide. It appears to us more reasonable to interpret the HI/CO ratio of 2 as meaning that formyl radicals react with iodine also to give hydrogen iodide, carbon monoxide and one iodine atom. A consideration of the bond strengths involved leads to the conclusion that such a reaction is very possible.

Experiments on known samples showed that methyl iodide was not removed by the solid potassium hydroxide; hence the iodide retained by the hydroxide must have come from hydrogen iodide. The molecular ratio of carbon monoxide to hydrogen iodide was always greater than unity, indicating that if the above hypothesis is correct some of the hydrogen iodide was removed by a reaction in which a condensable product is formed.

The absence of more than a trace of hydrogen, together with the constancy of quantum yields above 1 mm. of iodine pressure, shows that all secondary reactions are almost, if not completely, stopped. The small amount of methane found may have been produced either from secondary processes or by reaction (1a). Regardless of this, it seems evident that within about five per cent. the primary process quantum yield $\phi = \Phi_{\text{CH}_3\text{I}} = \Phi_{\text{CO}} = 0.20$. Since Φ_{CO} without iodine is greater than ϕ , it appears that recombination of methyl and formyl radicals cannot occur to an appreciable extent in pure acetaldehyde photolysis. The fact that only 20% of the absorbing molecules dissociate at $\lambda 3130$ is consistent with the diffuse character of the absorption spectrum in this re-

(6) Blacet and Volman, *THIS JOURNAL*, **60**, 1243 (1938).

(7) Blacet and Blaedel, *ibid.*, **62**, 3374 (1940).

gion.⁸ Since at best fluorescence can account for only a few per cent. of the total absorbed energy, collisional deactivation must be an important factor at this wave length.

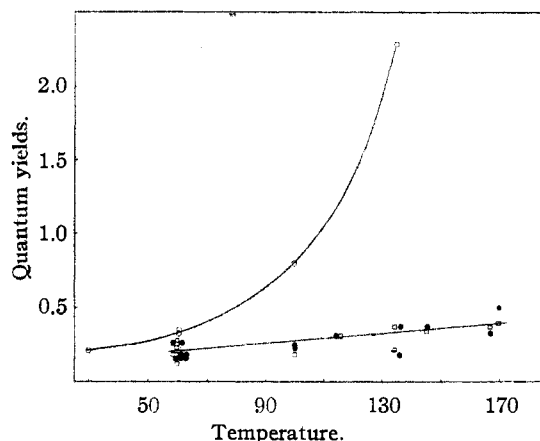
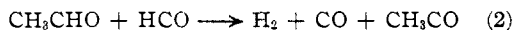
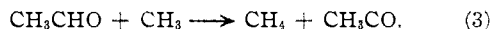

Fig. 2.—Quantum yields vs. temperature: O, quantum yield of carbon monoxide, without iodine; □, quantum yield of carbon monoxide with iodine present; ●, quantum yield of methyl iodide; λ 3130; acetaldehyde pressure, 200 mm.; iodine pressure, between 1 and 3 mm.; value at 30° from Leighton and Blacet.⁸

In Fig. 2 it can be seen that iodine is very effective in reducing the rate of acetaldehyde photodecomposition. Without iodine the radicals from reaction 1b are free to take part in reactions such as



and



As temperature is raised, the acetyl radical becomes more unstable, dissociating thus

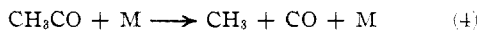

and a chain mechanism involving reactions (3) and (4) is set up. Considering the different procedures and conditions employed, the quantum yields obtained at 100° and above are in good agreement with those reported by Leermakers² and by Rollefson and Grahame.³ With sufficient iodine present, the above reactions cannot readily occur, since the steady state free radical concentrations are kept very low by the halogen. Consequently in the presence of iodine, Φ_{CO} has a comparatively constant value over the range 60 to 170°. Although experimental errors are fairly large, it appears from Fig. 2 that there is a small increase of quantum yields with temperature when iodine is present. This may be due to a

(8) Leighton and Blacet, *THIS JOURNAL*, **55**, 1766 (1933).

greater thermal effect on the primary yield in (1b); to a greater absorption coefficient at elevated temperatures³; to a slightly greater probability of reactions (2) and (3) occurring in the presence of iodine, or to a combination of these possibilities. The high values for $\Phi_{\text{CH}_3\text{I}}$ obtained around 170° suggest the third possibility mentioned above, combined perhaps with some thermal instability of methyl iodide in this temperature range. The apparent convergence of the two curves in Fig. 2 around room temperature indicates that there the chain contributes very little to the over-all quantum efficiency. The discrepancy between this conclusion and the one previously reached by Blacet and Blaedel⁷ can be accounted for at least in part by the fact that they worked at higher pressures and with the full radiation of the mercury arc.

The fact that Φ_{CO} equals $\Phi_{\text{CH}_3\text{I}}$ at each temperature at which the mixture was studied is another indication that formyl as well as methyl radicals react readily with iodine. Otherwise, the formyl groups would be expected to form some glyoxal and formaldehyde⁷ and the quantum yields then would not be numerically equal at all temperatures.

Summary

1. A study has been made of the photolysis of acetaldehyde and of acetaldehyde and iodine mixtures at λ 3130 over the temperature range of 60 to 170°.

2. For pure acetaldehyde at a concentration of 1.00×10^{-2} mole per liter, the quantum yield of carbon monoxide production, Φ_{CO} , increased from 0.34 at 60° to 2.29 at 135°.

3. With the introduction of iodine vapor into the reaction system at 60°, Φ_{CO} decreased at first with an increase of iodine concentration and then remained constant at 0.21 over the iodine pressure range of 1 to 3 mm. Simultaneously, with an iodine pressure increase from 0 to 1 mm., $\Phi_{\text{CH}_3\text{I}}$ decreased from 0.32 to an upper limit of 0.013. As the iodine concentration increased, the quantum yield of methyl iodide production, $\Phi_{\text{CH}_3\text{I}}$, increased from zero to 0.20 and remained constant at this value over the 1 to 3 mm. iodine range.

4. With sufficient iodine present, Φ_{CO} and $\Phi_{\text{CH}_3\text{I}}$ remained almost constant from 60 to 170°, increasing scarcely beyond the limits of experimental error over this range.

5. Additional analysis of the photolysis products of the mixture showed (1) that no more than

a trace of hydrogen is formed, (2) that acetyl iodide is not formed, and (3) that hydrogen iodide is produced in considerable quantity.

6. These results are interpreted to mean that, at $\lambda 3130$: (1) the formation of free methyl and formyl groups is the only important primary dissociation process, (2) iodine reacts readily with both methyl and formyl radicals, thus stopping all normal secondary processes, (3) iodine does

not react readily with activated acetaldehyde molecules, (4) the recombination of methyl and formyl radicals in normal photolysis does not occur to any great extent, (5) the primary dissociation quantum yield, ϕ , equals Φ_{CO} and Φ_{CH_3I} , and is approximately 0.20, and (6) collisional deactivation accounts for a large portion of the total absorbed radiant energy.

LOS ANGELES, CALIF.

RECEIVED JANUARY 2, 1942

[CONTRIBUTION FROM THE CHEMISTRY DEPARTMENT, UNIVERSITY OF CALIFORNIA, LOS ANGELES]

The Photolysis of the Aliphatic Aldehydes. XI. Acetaldehyde and Iodine Mixtures

BY F. E. BLACET AND DONALD E. LOEFFLER

This article pertains to photolysis experiments on acetaldehyde and iodine mixtures in which wave length, temperature and iodine concentration were varied one at a time while other conditions remained constant. The major portion of this work was done at $\lambda 2654$. Except for a few minor differences, the apparatus and experimental methods employed in the work were the same as given in the preceding article of this series¹ and need not be described here.

Experimental Results

In Tables I and II are given quantum yields of carbon monoxide, methane and methyl iodide production obtained under various conditions. In all runs the acetaldehyde concentration was approximately 1.00×10^{-2} mole per liter and the incident intensity was about 7.0×10^8 ergs per second.

In the presence of 1 mm. or more of iodine vapor the average quantum yield of hydrogen formation was 0.02. It is doubtful if this value is outside the limits of experimental error. Hydrogen iodide was qualitatively detected to be a photolysis product of the mixture. A small amount of condensed material was observed to form in the reaction cell during the photochemical process. This polymer-like material was found to give a positive test for free iodine and for a trace of iodide ion. The amount of free iodine in this substance was small compared to the total amount added to the system and the iodide present probably accounts for the failure to get reproducible results for hydrogen iodide in the condensed vapors. Dark runs at 60° showed no reaction between

acetaldehyde and iodine when both substances were in the vapor phase.

In the study of acetaldehyde and iodine mixtures experimental errors were somewhat larger than those obtained in the study of pure acetaldehyde. However, as shown in the accompanying figures, by averaging results obtained for each set

TABLE I
VARIATIONS OF QUANTUM YIELDS WITH IODINE PRESSURE WITH TEMPERATURE AT WAVE LENGTH 2654 Å.

| Run | Temp., °C. | Pressure of iodine, mm. | Φ_{CO} | Φ_{CH_4} | Φ_{CH_3I} |
|-----|------------|-------------------------|-------------|---------------|----------------|
| 1 | 58 | 0.24 | 0.60 | 0.56 | |
| 2 | 58 | .26 | .73 | | 0.32 |
| 3 | 58 | .30 | .60 | .35 | .22 |
| 4 | 60 | .43 | .63 | .21 | |
| 5 | 58 | .43 | .70 | .41 | .07 |
| 6 | 57 | .87 | .38 | | .35 |
| 7 | 61 | .89 | .66 | .25 | |
| 8 | 58 | 1.02 | .67 | .37 | .27 |
| 9 | 57 | 1.4 | .58 | .26 | .35 |
| 10 | 57 | 1.7 | .52 | | .20 |
| 11 | 57 | 1.7 | .78 | .25 | |
| 12 | 61 | 1.9 | .77 | .29 | .44 |
| 13 | 57 | 2.0 | .64 | .28 | |
| 14 | 58 | 2.2 | .74 | | .44 |
| 15 | 61 | 2.4 | .68 | .24 | .43 |
| 16 | 58 | 2.4 | .55 | .22 | .31 |
| 17 | 60 | 2.5 | .70 | .32 | |
| 18 | 100 | 1.7 | .75 | .31 | .31 |
| 19 | 100 | 1.6 | .61 | .28 | .18 |
| 20 | 100 | 1.6 | .42 | .28 | .38 |
| 21 | 125 | 1.4 | .74 | .34 | .34 |
| 22 | 125 | 1.8 | .71 | .30 | .49 |
| 23 | 150 | 1.9 | .64 | .29 | .44 |
| 24 | 150 | 1.9 | .79 | .27 | .53 |
| 25 | 57 | 0.0 | .78 | .79 | |
| 26 | 100 | .0 | 1.25 | 1.00 | |
| 27 | 125 | .0 | 3.20 | 2.69 | |
| 28 | 150 | .0 | 5.85 | 4.53 | |

(1) Blacet and Heldman, *THIS JOURNAL*, **64**, 889 (1942).